

Ordered by:

Westech Components Wuxi Co., Ltd.
4F, B2 Building
Liyuan Economic Development Zone
CN-214072 Wuxi, Jiangsu

Tel. +86 510 85166098
Fax: +86 510 85166176

Test Report No. C829QPEN

Tests according to EN 12975-2: 2006, Paragraph 5

Content:	page
1 Description of Collector	2
1.1 Technical Data of Sample	2
1.2 Sketch of Collector	3
1.3 Specifications on Elements	3
1.4 Photo of Collector	4
1.5 Sketch of Collector Mounting	4
1.6 Labelling	5
1.7 Safety	5
1.8 Installer Instruction Manual	5
2 Test Methods and Results	6
2.1 Tests of Durability	6
2.2 Test Sequence and Summary	6
2.3 Internal Pressure Test	7
2.4 High-Temperature Resistance Test	7
2.5 Exposure Test	8
2.6 External Thermal Shock	10
2.7 Internal Thermal Shock	11
2.8 Rain Penetration Test	12
2.9 Mechanical Load Test	12
2.10 Final Inspection	13
3 Remarks	13

1 Description of Collector

1.1 Technical Data of Sample

Product information		Absorber	
Manufacturer	Westech Components Wuxi Co., Ltd.	Absorber element	Evacuated double glass tube
Model	SP-S58/1800A-22	Length of absorber element	1720 mm
Type	Evacuated tube collector	Width of absorber element	47.0 mm
Flow	Heat Pipe	Thickness of absorber element	1.5 mm
Serial product	Yes	Coating	Aluminiumnitride on Al
Drawing number	A set of technical drawings is filed at the test institute.	Flowed through element	Copper pipe/Heat pipe
Serial number	--	Joining technique	Heat conducting aluminum sheets
Date of manufacture	01.09.2006	Joining seam	--
Physical parameters		Installation	
Gross length	1.970 m	On tilted roof	Yes
Gross width	1.846 m	In tilted roof	No
Gross height	0.155 m	On flat roof	No
Gross area	3.637 m ²	On flat roof with stand	No
Aperture area	2.074 m ²	Facade	No
Absorber area	1.790 m ²	Casing and insulation	
Weight empty	76.5 kg	Casing material	Aluminium
Fluid capacity	1.4 l	Sealing material	EPDM
Construction		Insulation material	Rockwool compression-molded
Type	Evacuated tube collector	Thickness (in mm)	50
Number of absorber elements	22	Aperture dimensions	1.720 m * 0.0548 m * 22
Absorber pitch	80 mm	Limitations (manufacturers' information)	
Number of hydraulically parallel tubes	1	Max. temperature	220°C
Number of thermally serial glazings	1	Max. pressure	6 bar
Material of glazing(s)	Borosilicate glass	Other	--
Thickness of glazing(s)	1.6 mm	Remarks on collector design	
Heat transfer fluid (manufacturers' recommendation)		--	
Type	Water-antifreeze	Test schedule	
Specifications	--	Test procedure	EN12975:2006, Outdoor test
Flow (manufacturers' recommendation)		Sample received	22.12.2006
Flow range	132 - 264 l/h	Start of test	05.03.2007
Rated flow	132 l/h	End of test	16.07.2007

1.2 Sketch of Collector

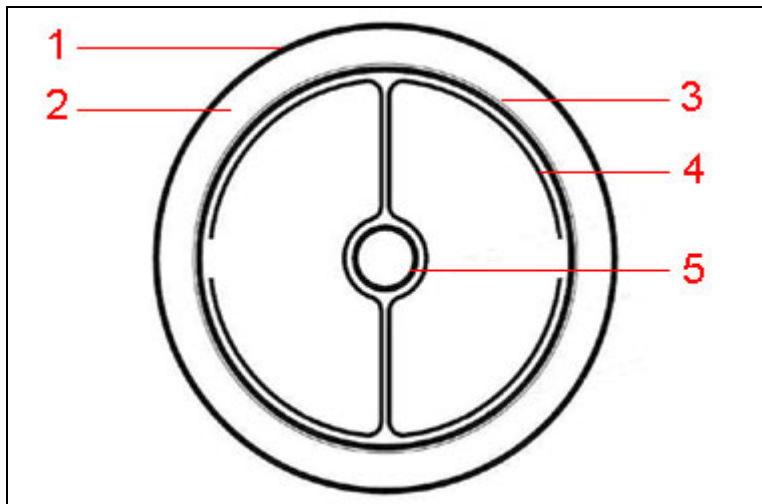

1.3 Specifications on Elements

1	Glazing Material: Thickness [mm]:	Borosilicate glass 1.6
2	Vacuum	
3	Absorber coating Description: Manufacturing process:	Aluminiumnitride on Al Sputtering
3	Absorber Absorber element: Flow-through element: Length of element [mm]: Width of element [mm]: Flow type: Joining technique:	Evacuated double glass tube Copper pipe/Heat pipe 1720 47 Serial Heat conducting aluminum sheets
4	Heat-conducting metal sheet Description:	Aluminum
5	Heat pipe Description:	Copper

1.4 Photo of Collector



1.5 Sketch of Collector Mounting

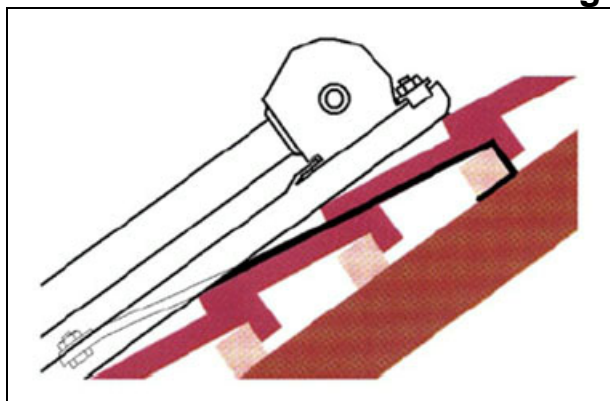

1.6 Labelling

The collector carries a label.	Yes
The label is visible.	Yes
The label is durable.	No

The label includes the following information:

Name of manufacturer	Yes
Collector type	Yes
Serial number	Yes
Year of production	No
Gross area of collector	Yes
Maximum operating pressure	Yes
Stagnation temperature for 1000 W/m ² and 30°C	Yes
Volume of heat transfer fluid	Yes
Weight of empty collector	Yes
Made in ...	Yes

1.7 Safety

The collector provides for safe installation and mounting. It has no sharp edges, no loos connections, and no other potentially dangerous features.	Yes
If the weight of the empty collector exceeds 60 kg an anchorage for a lifting device is included, except for collectors that are assembled on the roof.	Yes
If the collector is made to be filled with a heat transfer fluid that is irritant to human skin or eyes or that is toxic, the collector carries a warning label.	Yes

1.8 Installer Instruction Manual

The collector is accompanied by an installer instruction manual.	Yes
--	-----

The installer instruction manual includes the following information:

Dimensions and weight of the collector	Yes
Instructions about the transport and handling	Yes
Description of the mounting procedure	Yes
Recommendations about lightning protection	No
Instructions about the coupling of several collectors (up to 20 m ²).	No
Instructions for the connection of the collector field to the heat transfer circuit (up to 20 m ²).	No
Instructions for the dimension of the pipe connections for collector arrays (up to 20 m ²).	No
Recommendation about the heat transfer (also with respect to corrosion)	Yes
Precautions to be taken during filling, operation and service.	No
Maximum operating pressure	Yes
Pressure drop	No
Maximum and minimum tilt angle	Yes
Permissible wind and snow loads	Yes
Maintenance requirements	Yes
The documentation is available in the national language of the country where the collector is sold. (Manufacturers' information)	Yes

2 Test Methods and Results

2.1 Tests of Durability

The tests are carried out according to the EN 12975-2:2006, Chapter 5.

*Deviations from these test directions are marked with an *) and highlighted by italic writing.*

2.2 Test Sequence and Summary

Test	Date of test	Chap. of standard	Result	
Internal pressure	05.03.2007	5.2	Passed	
High-temperature resistance	10.04.2007	5.3	Passed	
Exposure	05.03.2007 – 13.04.2007	5.4	Passed	
External thermal shock	Shock Nr.1 Shock Nr.2	30.03.2007 30.03.2007	5.5	Passed Passed
	Internal thermal shock	Shock Nr.1 Shock Nr.2	26.03.2007 28.03.2007	5.6
Rain penetration		16.07.2007	5.7	Passed
Freeze resistance	--	5.8	n/a	
Thermal performance	05.02.2007 - 26.04.2007	6.1 - 6.2 - 6.3	Passed	
Impact resistance	--	5.10	n/a	
Mechanical load	16.07.2007	5.9	Passed	
Final inspection	16.07.2007	5.11	Passed	

Remarks	The test sequence may have been adapted to the internal requirements of the test institute. The test "Thermal performance" may have been made with a conformity-checked second collector.
---------	---

2.3 Internal Pressure Test

2.3.1 Remarks

--

2.3.2 Technical details of collector

Glazed/unglazed?	Glazed
Maximum operation pressure (Manufacturers' information)	6 bar

2.3.3 Test conditions

Surrounding temperature	20°C
Test pressure	9 bar
Duration	15 min

2.3.4 Test results

Observations	None
Major failures according to 5.3.1 of EN12975-1:2006	None

2.4 High-Temperature Resistance Test

2.4.1 Remarks

Outdoor test

Temperature sensor attached to the manifold pipe. Direct measurement of the absorber temperature is not possible.

2.4.2 Test conditions

Collector tilt angle (degrees from horizontal)	44.4°
Average irradiance during test	1038 W/m ²
Minimum irradiance during test	1020 W/m ²
Average surrounding air speed	1.5 m/s
Average surrounding temperature	21.9°C
Minimum surrounding temperature	21.3°C
Average absorber temperature	209.2°C
Duration of test	>60 min

2.4.3 Test results

Observations	None
Major failures according to 5.3.1 of EN12975-1:2006	None

2.4.4 Determination of stagnation temperature

Temperature sensor attached to the manifold pipe

Stagnation temperature for 30°C/1000 W/m ² Determined according to Annex C.2 of EN12975-2:2006	211°C
--	-------

2.5 Exposure Test

2.5.1 Remarks

Outdoor exposure test. Collector installed on a tracker.

2.5.2 Test conditions

Part A	Exposition for at least 30 days with a minimum daily irradiation $H \geq 14 \text{ MJ/m}^2$.
Part B	Exposition for at least 30 hours at irradiance $G \geq 850 \text{ W/m}^2$ and ambient temperature $T_{\text{amb}} \geq 10^\circ\text{C}$. The minimum duration of every period is $\Delta t \geq 30 \text{ min}$.

2.5.3 Climatic conditions for all days during the test (Part A)

Date	H [MJ/m ²]	T _{amb} [°C]	Rain [mm]	Valid days
05.03.2007	2.9	7.8	0.0	0
06.03.2007	15.4	6.2	0.0	1
07.03.2007	5.5	8.3	8.0	1
08.03.2007	2.1	7.5	4.0	1
09.03.2007	19.2	6.9	0.0	2
10.03.2007	12.1	5.8	9.0	2
11.03.2007	25.1	5.2	0.0	3
12.03.2007	18.0	5.4	0.0	4
13.03.2007	15.6	7.9	0.0	5
14.03.2007	14.0	8.0	0.0	6
15.03.2007	14.0	8.2	0.0	7
16.03.2007	15.7	9.1	0.0	8
17.03.2007	11.6	9.0	0.0	8
18.03.2007	14.0	7.8	1.0	9
19.03.2007	9.0	3.4	11.0	9
20.03.2007	3.8	1.1	5.0	9
21.03.2007	19.0	2.9	4.0	10
22.03.2007	10.5	2.9	1.0	10
23.03.2007	5.7	2.6	5.0	10
24.03.2007	14.1	3.6	3.0	11
25.03.2007	21.7	5.5	0.0	12
26.03.2007	14.8	6.4	0.0	13
27.03.2007	25.8	8.4	0.0	14
28.03.2007	26.5	8.0	0.0	15
29.03.2007	27.0	9.9	0.0	16
30.03.2007	21.8	9.6	0.0	17
31.03.2007	23.9	6.4	0.0	18
01.04.2007	30.8	8.6	0.0	19
02.04.2007	31.7	11.0	0.0	20
03.04.2007	20.0	10.0	0.0	21
04.04.2007	7.3	6.7	2.0	21
05.04.2007	19.5	8.7	0.0	22
06.04.2007	33.1	10.4	0.0	23
07.04.2007	32.5	12.8	0.0	24
08.04.2007	18.9	11.9	0.0	25
09.04.2007	28.8	12.6	0.0	26

10.04.2007	33.3	14.0	0.0	27
11.04.2007	24.0	14.0	0.0	28
12.04.2007	32.6	15.5	0.0	29
13.04.2007	32.6	17.4	0.0	30

2.5.4 Climatic conditions for all days during the test (Part B)

Date / Time	G [W/m ²]	T _{amb} [°C]	Δt [min]	Sum [min]
06.03.2007 12:33:00-13:20:00	1051.1	10.9	47.0	47.0
06.03.2007 13:49:00-14:47:00	1007.5	12.1	58.0	105.0
09.03.2007 11:28:30-12:49:00	1029.6	11.1	80.5	185.5
11.03.2007 13:41:00-15:40:30	1002.3	12.0	119.5	305.0
12.03.2007 11:54:30-15:39:30	1050.7	13.2	225.0	530.0
13.03.2007 10:34:00-11:44:00	1045.6	11.0	70.0	600.0
13.03.2007 11:55:30-14:18:00	1055.7	13.1	142.5	742.5
13.03.2007 14:20:00-14:55:30	1018.1	16.5	35.5	778.0
14.03.2007 10:49:30-15:01:30	976.9	13.2	252.0	1030.0
15.03.2007 10:56:30-14:44:30	948.0	13.0	228.0	1258.0
16.03.2007 10:38:30-11:10:00	890.5	10.4	31.5	1289.5
16.03.2007 11:18:00-13:32:00	913.5	12.2	134.0	1423.5
18.03.2007 10:04:30-10:47:30	1009.3	10.9	43.0	1466.5
18.03.2007 11:17:00-13:31:30	1049.1	14.2	134.5	1601.0
26.03.2007 10:59:30-14:14:30	1085.4	11.6	195.0	1796.0
26.03.2007 15:15:00-16:07:00	918.3	14.6	52.0	1848.0

2.5.5 Test results

2.5.5.1 Observations and evaluation

Evaluation according to the following key:

0 – no problem

1 – Minor problem

2 – Severe problem

* – Inspection or evaluation was not possible

Collector component	Potential problem	Result
Collector box / fasteners	Cracking / warping / corrosion / rain penetration	0
Collector mounting / structure	Strength / safety	0
Seals / gaskets	Cracking / adhesion / elasticity	0
Covers / reflectors	Cracking / crazing / buckling / delamination / warping / outgassing	0
Absorber coating	Cracking / crazing / blistering	0
Absorber tubes and headers	Deformation / corrosion / leakage / loss of bonding	0
Absorber mountings	Deformation / corrosion	0
Insulation	Water retention / outgassing / degradation	0
Major failures according to 5.3.1 of EN12975-1:2006		None

2.6 External Thermal Shock

2.6.1 Remarks

Shock-Nr.1:	Outdoor test Temperature sensor attached to the manifold pipe. Direct measurement of the absorber temperature is not possible.
Shock-Nr.2:	Outdoor test Temperature sensor attached to the manifold pipe. Direct measurement of the absorber temperature is not possible.

2.6.2 Test conditions

Shock-Nr.		1	2
Conditioning phase			
Collector tilt angle	°	44.3	47.4
Average irradiance	W/m ²	1059	1045
Minimum irradiance	W/m ²	904	993
Average surrounding temperature	°C	13.2	15.5
Minimum surrounding temperature	°C	11.7	14.9
Period during which the required conditions were maintained before the shock	min	> 60	> 60
Shock			
Spray rate	l/(s·m ²)	0.03 - 0.05	0.03 - 0.05
Temperature of water spray	°C	approx. 15	approx. 15
Duration of water spray	min	15	15
Absorber temperature prior to the shock	°C	205.8	206.2
Test combined with „Exposure Test“			
		No	No
Test combined with „High-Temperature Resistance Test“			
		No	No

2.6.3 Test results

Observations	Shock Nr.1	None
	Shock Nr.2	None
Major failures according to 5.3.1 of EN12975-1:2006	Shock Nr.1	None
	Shock Nr.2	None

2.7 Internal Thermal Shock

2.7.1 Remarks

Shock-Nr.1:	Outdoor test Temperature sensor attached to the manifold pipe. Direct measurement of the absorber temperature is not possible.
Shock-Nr.2:	Outdoor test Temperature sensor attached to the manifold pipe. Direct measurement of the absorber temperature is not possible.

2.7.2 Test conditions

Shock-Nr.		1	2
Conditioning phase			
Collector tilt angle	°	51.3	57.3
Average irradiance	W/m ²	1064	961
Minimum irradiance	W/m ²	1042	942
Average surrounding temperature	°C	12.3	16.1
Minimum surrounding temperature	°C	11.6	15.8
Period during which the required conditions were maintained before the shock	Min	> 60	> 60
Shock			
Flow rate of water	l/(s·m ²)	≥ 0.02	≥ 0.02
Temperature of water prior to the shock	°C	approx. 15	approx. 15
Duration of water flow	Min	5	5
Absorber temperature prior to the shock	°C	209.1	200.2
Test combined with „Exposure Test“			
		No	No
Test combined with „High-Temperature Resistance Test“			
		No	No

2.7.3 Test results

Observations	Shock Nr.1	None
	Shock Nr.2	None
Major failures according to 5.3.1 of EN12975-1:2006	Shock Nr.1	None
	Shock Nr.2	None

2.8 Rain Penetration Test

2.8.1 Remarks

Outdoor test.

The collector is installed on an open frame. Spraying from all sides.

In-roof collectors only: No spraying from the rear side.

2.8.2 Test conditions

Collector tilt angle (degrees from horizontal)	30°
Flow rate of water	$\geq 0.05 \text{ l/(s}\cdot\text{m}^2)$
Temperature of water spray	$< 30^\circ\text{C}$
Duration	4 h

2.8.3 Determination of water penetration

Detection of ingress of water by the following method(s)

- Visual inspection
- Determination of the amount of water ingress.

2.8.4 Test results

Observations	Acceptable accumulation of water inside the collector ($< 30 \text{ g/m}^2$).
Major failures according to 5.3.1 of EN12975-1:2006	None

2.9 Mechanical Load Test

2.9.1 Remarks

The methods for the mechanical load tests described in the norm are not applicable for evacuated tube collectors. The ability to withstand mechanical loads is therefore theoretically assessed considering the mechanical construction.

Based on the experience of the test institute the construction of the collector itself, as well as of the fixings of the collector, are such that the mechanical loads (positive and negative loads) similar to the loads prescribed by the norm would not lead to any damage. The mechanical load test is therefore considered as passed.

2.10 Final Inspection

2.10.1.1 Observations and evaluation

Evaluation according to the following key:

0 – no problem

1 – Minor problem

2 – Severe problem

* – Inspection to establish the condition was not possible

Collector component	Potential problem	Result
Collector box / fastener	Cracking / warping / corrosion / rain penetration	0
Collector mounting / structure	Strength / safety	0
Seals / gaskets	Cracking / adhesion / elasticity	0
Covers / reflectors	Cracking / crazing / buckling / delamination / warping / outgassing	0
Absorber coating	Cracking / crazing / blistering	0
Absorber tubes and headers	Deformation / corrosion / leakage / loss of bonding	0
Absorber mountings	Deformation / corrosion	0
Insulation	Water retention / outgassing / degradation	1

3 Remarks

This report must not be copied except in full.

The test methods applied fulfil the requirements of EN12975:2006.

The test results only refer to the tested collector sample.

This test report is made according to the requirements of EN12975:2006.

This test report fulfils the requirements of ISO17025.

Rapperswil, 22.08.2007



Dr. Andreas Bohren
Head of SPF Testing



Dipl.-Ing. Walter Gubler
Test engineer